

**μPD78 series microcontroller EEPROM Programmer**

**User's Guide**

## TABLE OF CONTENTS

1. PREFACE	3
2. CHECKLIST AND REQUIREMENTS	3
3. INSTALLATION AND USE	4
3.1 PROGRAMMER CHECK AND CONNECTION TO PC	5
3.2 PROGRAMMER FIRMWARE UPDATE	5
4. INTERFACE TYPES	6
4.1 IN-CIRCUIT PROGRAMMING	5
5. WORKING WITH TARGET MCU	7
5.1. In-Circuit EEPROM reading example	7
5.1.2 In-Circuit EEPROM programming example	7
6. FILE OPERATIONS	8
6.1 LOAD FILE INTO BUFFER	8
6.2 SAVE FILE FROM BUFFER	8
7. ERRORS AND TROUBLESHOOTING	9
8. WARRANTY STATEMENT	11
9. APPENDIX	12
In-Circuit wiring diagram for uPD780973 MCU	12
In-Circuit wiring diagram for uPD78(F)0948/49 MCU	13
In-Circuit wiring diagram for uPD780828A MCU	14

## 1. PREFACE

This manual will guide you through the installation and operation of the ETL uPD780973 Programmer, referenced hereafter as the **uPD78-Programmer**.

The **uPD78-Programmer** has been designed for Reading, Programming of EEPROM contents of the next NEC Microcontroller Unit (MCU):

- ✓ uPD780973
- ✓ uPD780949
- ✓ uPD78F0949
- ✓ uPD78F0828A M1



**Note:** Devices that not mentioned above in list can't be guaranteed of correct reading, programming by **uPD78-Programmer**.

## 2. CHECKLIST AND REQUIREMENTS

The following describes what items are supplied with the **uPD78-Programmer**:

- ✓ **uPD78-Programmer** – *supplied*
- ✓ Cable -A DB9 “straight-thru” cable - *supplied*
- ✓ **uPD78-Programmer** PC software on CD-ROM – *Optional Extra*

The PC system requirements :

- Desktop PC and a free Serial Communication Port (COM1...8)
- Memory - Minimum 32 Mbytes
- Display - Color SVGA display recommended
- Preinstalled DWG Viewer 3.0 software\*
- Power supply 12 Volt/500 mA linear power supply source
- OS -MS-Windows (Win98, Win2000/XP)



**Note:** Free DWG Viewer 3.0 software can be downloaded from <http://www.etlweb.com/files/viewers/dwgviewer.zip>

### 3. INSTALLATION AND USE

The uPD78-Programmer includes two LED's and mode jumper (Figure 1). Color LED's indicates programmer state and external power supply voltage (Table 1, 2).

<b>GREEN</b>	uPD78-Programmer is ready.
<b>GREEN Flashing</b>	uPD78-Programmer is busy.
<b>DARK</b>	Voltage applied to uPD78-Programmer lower than 6 Volt.

Table 1. LED D2 color meaning

<b>GREEN</b>	All signals on In-Circuit Programmer connector are active.
<b>DARK</b>	Signals on In-Circuit Programmer connector are deactivated (in three state).

Table 2. LED D3 color meaning

Jumper-1 (JP1) is intended for uPD78-Programmer mode selection (see Table 3).

<b>JP1 Shorted</b>	Normal operation. NEC device EEPROM Reading/Programming.
<b>JP1 Opened</b>	Service mode. uPD78-Programmer firmware update.

Table 3. uPD78-Programmer operation modes

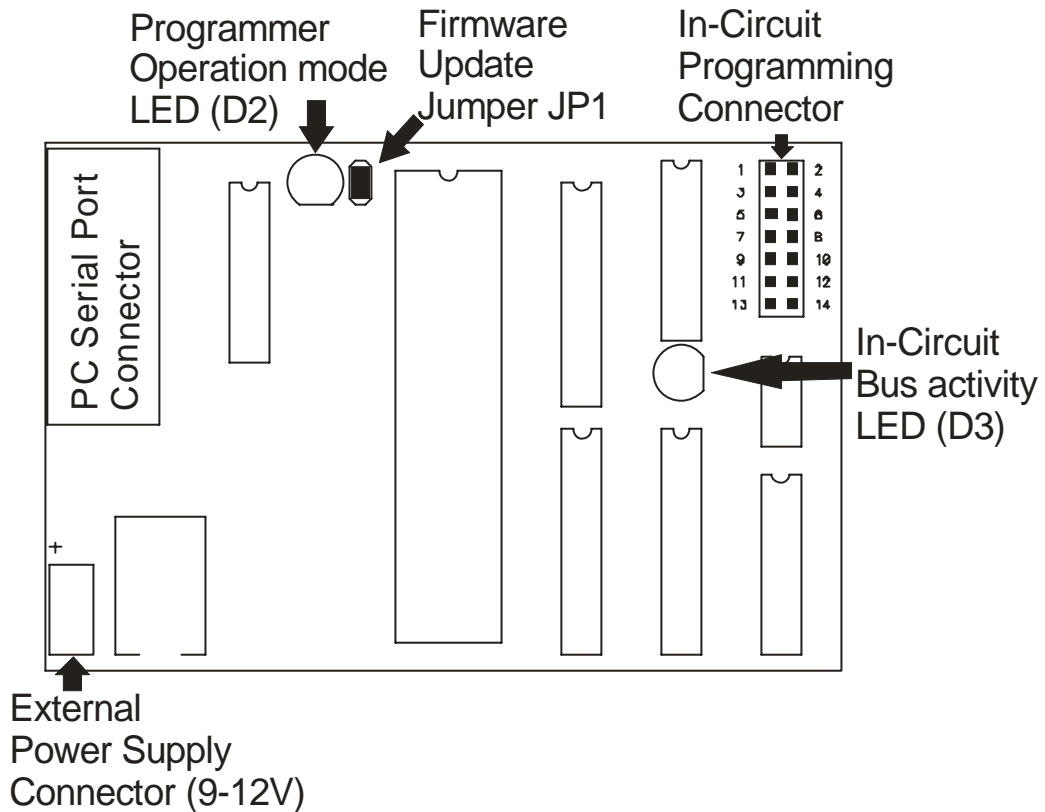

Figure 1. The uPD78-Programmer board layout

### 3.1 PROGRAMMER CHECK AND CONNECTION TO PC

- Connect the power supply source to uPD78-Programmer (an external 12 V DC power supply source is required).
- Attach a COM port cable to the 9-pin connector on the programmer and to a COM port on the PC.
- Insert jumper JP1 (see Figure 1).
- Turn On power supply source and make sure that LED D1 appear green.
- Start uPD78-Programmer software.
- After few seconds you should see on display message: “uPD780973 Programmer Ver-X.X detected”.
- In case when you should see message: “uPD780973 Programmer Ver-X.X not found”, change COM port number. To do that select “Tools” menu item and than select “Comm Port Options”. Select new COM port number. After pressing “OK” button the new setting will be applied and software reattempts connection with programmer.
- Now uPD78-Programmer ready to operate.



**Note:** Update uPD78-Programmer firmware if required (see Section 3.2).

### 3.2 PROGRAMMER FIRMWARE UPDATE

This section describes how to update firmware (ATMEGA 16) of uPD78-Programmer.

- Remove JP1 (see Figure 1).
- Turn On power supply; make sure that LED D1 appears green.
- Start uPD78-Programmer software.
- Compare firmware version “uPD780973 Programmer Ver-X.X detected” and version specified in “Help>About” menu item.
- If versions not coincide, follow next steps to update firmware.
- Select menu item “Tools>Firmware Update”.
- After message box “Firmware Update” appeared, press “OK” button.
- After firmware update completed, turn off power supply, close uPD78-Programmer software.
- Insert JP1.
- Turn On power supply. Make sure that LED1 appear green.
- Start uPD78-Programmer software on PC. New firmware version “uPD780973 Programmer Ver-X.X detected” will appear.

## 4. INTERFACE TYPES

This section describes In-Circuit Programming (ICP) interface, of uPD78-Programmer.

### 4.1 IN-CIRCUIT PROGRAMMING

In-Circuit programming interface is basic for uPD78-Programmer. With this interface uPD78-Programmer automatically detects target MCU bus speed. Ceramic resonator connected to NEC MCU must be in range from 4 MHz to 8.372 MHz. Signals required for communication with target MCU described in Table 3.

PIN number	Programmer Signal Description
1	Communication Pin1
2	Communication Pin2
3	Communication Pin3
4	Communication Pin4
5	Communication Pin5
6	Communication Pin6
7	Communication Pin7
8	Communication Pin8
9	IC Pin(Factory test mode)
10	Reset Pin
11	Communication Pin9
12	Communication Pin10
13	Built-in power supply +5V (Vcc).
14	Signal Ground (Vdd)

Table 3. Pin functions of uPD78-Programmer ICP connector

## 5. WORKING WITH TARGET MCU

This section contains overall information about NEC78 MCUs supported by uPD78-Programmer. When uPD78-Programmer successfully installed (see Section 3) target devices can be read, program and verify.

### 5.1 In-Circuit EEPROM reading example

- Connect required pins to board with target MCU (see Appendix).
- Apply power to uPD78-Programmer. LED D2 became to green light (see Table 1).
- Select corresponding device in uPD78-Programmer software (“Device” button).
- Select “Read Sequence” panel in uPD78-Programmer software.
- Press “EEPROM” button.
- Press “Start” button.
- LED D3 on uPD78-Programmer became to green light. That means that +5 voltage regulator switched on and VCC applied to target MCU.
- Now uPD78-Programmer automatically detects MCU bus speed.
- When LED D2 on uPD78-Programmer became permanent green, reading completed. Target MCU powered off.
- After read sequence successfully completed it is necessarily to save memory dump to file (see Section 6.2).
- If some errors appeared during reading process refer to Section 7.

### 5.2 In-Circuit EEPROM programming example

- Connect required pins to board with target MCU (see Appendix).
- Apply power to uPD78-Programmer. LED D2 became to green light (see Table 1).
- Select corresponding device in uPD78-Programmer software (“Device” Button).
- Load EEPROM data from file (see Section 6.1) or enter data to Hex Editor.
- Select “Program Sequence” panel in uPD78-Programmer software.
- Press “EEPROM” button.
- Press “Start” button.
- LED D3 on uPD78-Programmer became to green light. That means that +5 voltage regulator switched on and VCC applied to target MCU.
- Now uPD78-Programmer automatically detects MCU bus speed.
- When LED D2 on uPD78-Programmer became permanent green, programming completed. Target MCU powered off.
- If some errors appeared during programming process refer to Section 7.



**Note:** Strongly recommended before EEPROM programming, for a first time, read EEPROM contents and save it to file.

## 6. FILE OPERATIONS

This section describes basic rules working with files. Memory dump from Hex Editor (Buffer) can be load/save from/to hard disk. Also short descriptions such as project name, MCU type and memory cell assignment can be done for future fast remind. **uPD78-Programmer** accepts tree types of file formats:

- ✓ BIN (Binary format)
- ✓ Motorola S-Record (4 byte address)
- ✓ Motorola S-Record (6 byte address)
- ✓ EEF (Extended ETL Format)

### 6.1 LOAD FILE INTO BUFFER

- Select “File>Open” menu item.
- Press “Browse” button.
- In File Open Dialog window, select file witch need to be open.
- Press “Open” button.
- Than opposite “Auto Format Detected:” text, select correct file format. Note that software try automatically detects file format, but unknown records in file will fail this detection. “Load Entire file” check box must be checked if automatically loading procedures required.
- Than press “OK” button.

Sometimes load data from file to specific buffer allocations required. For Example if required load buffer from \$F900 address from binary file beginning from \$0000 address follow next steps:

- Select “File>Open” menu item.
- Press “Browse” button.
- In File Open Dialog window, select file which need to be open.
- Press “Open” button.
- Than, opposite “Auto Format Detected:” select Binary format.
- Uncheck “Load Entire File” check box.
- In field “Offset Value to Place Data to Buffer:” enter 0xF900.
- Than press “OK” button.
- Now data placed to Hex Editor Buffer from the beginning of 0x0400 address.

If more complicated operations with files required, for example load Hex Editor Buffer from many files “Lowest Address From File To Load”, “Highest Address From File To Load” and “Clear Buffer Before Loading File” options are available.

### 6.2 SAVE FILE FROM BUFFER

- Select “File>Save” menu item.
- Press “Browse” button.
- Select directory in which file will be saved.
- Type file name, for example “test1”
- Press “Save” button.
- Than select format in which file will be saved\*.
- Press “OK” button.



**Note:** Use EEF Format for future “Load File Into Buffer” automatically processing. Also, only in EEF Format Project Description, Device Name and Memory Cells attributes can be saved.



## 7. ERRORS AND TROUBLESHOOTING

This section describes most recently encountered problems, errors and fixing solutions.

- **Problem:** LED D1 (see Figure 1) Dark.
- **Causes:** This problem can accrue when external power supply connected to **uPD78-Programmer** is damaged or connected in wrong polarity.
- **Solutions:** Check voltage on **uPD78-Programmer** power clamps. It must be 9-12 V.
  
- **Error Message:** uPD780973 Programmer not found.
- **Causes:** This message can appear when **uPD78-Programmer** software couldn't establish connection with **uPD78-Programmer** board.
- **Solutions:** Check connection of COM port cable from PC to **uPD78-Programmer** board. Apply power from external power supply to **uPD78-Programmer**. In menu item "Tools>Comm Port Options" select correct COM port number.
  
- **Error Message:** Communication Error.
- **Causes:** This message can appear when Communication between **uPD78-Programmer** and PC is broken.
- **Solutions:** Check COM port cable connection to board and PC. If message not disappear restart the computer.
  
- **Error Message:** IC Pin must be in 'high' state (line 9).
- **Causes:** This message can appear when MCU IC pin connected to ground through external components.
- **Solutions:** Cut any component from IC pin.
  
- **Error Message:** Reset Pin must be in 'high' state (line 10).
- **Causes:** This message can appear when MCU Reset pin connected to ground through external components.
- **Solutions:** Cut any component from Reset pin.
  
- **Error Message:** External Reset Occurred. Disconnect Reset pin (line 10) from external circuit.
- **Causes:** This message can appear when in time on reading/programming reset pulse appeared on MCU Reset pin from external circuit.
- **Solutions:** Cut any component and traces from Reset pin.
  
- **Error Message:** Parallel Communication Lines (1-8) Setup Error.
- **Causes:** This message can appear when communication lines 1-8 (see Table 3) pin connected to ground or Vcc through external components.
- **Solutions:** Cut any component from pins.

- **Error Message:** Pin Tester Errors.

■ **Causes:** This message can appear when NEC MCU pin(s) connected to ground or Vcc through external components.

■ **Solutions:** Cut any component from pin. To find out what pin must to be disconnected refer to Table 3 and Appendix.
  
- **Error Message:** Echo Error.

■ **Causes:** This message can appear when programmer communication line 11 connected to ground or Vcc through external components. Or ceramic resonator on NEC MCU has frequency instability.

■ **Solutions:** Cut any component from pin. To find out what pin must to be disconnected refer to Table 3 and Appendix. Or replace ceramic resonator connected to NEC MCU.
  
- **Error Message:** No Echo From Device.

■ **Causes:** This message can appear when programmer lines connected in wrong way with NEC MCU or wrong device selected in PC software.

■ **Solutions:** Check lines connected to MCU and device selected in Device dialog on PC. Try to reconnect by pressing "Start" Button
  
- **Error Message:** Target Device Speed too low.

■ **Causes:** This message can appear when ceramic resonator frequency connected to NEC MCU is too low.

■ **Solutions:** Replace ceramic resonator with frequency from 4-8 MHz.
  
- **Error Message:** Readout time-out Error.

■ **Causes:** This message can appear when NEC MCU do not respond long time.

■ **Solutions:** Check lines connected to MCU and try to reconnect by pressing "Start" Button
  
- **Error Message:** Transmitter time-out Error.

■ **Causes:** This message can appear when NEC MCU do not respond long time.

■ **Solutions:** Check lines connected to MCU and try to reconnect by pressing "Start" Button
  
- **Error Message:** Programming time-out Error.

■ **Causes:** This message can appear when NEC MCU do not respond long time.

■ **Solutions:** Check lines connected to MCU and try to reconnect by pressing "Start" Button
  
- **Error Message:** Programming Error.

■ **Causes:** This message can appear when programming of EEPROM completed with errors.

- **Solutions:** Try to repeat programming sequence. If error still exists replace ceramic resonator to 8MHz frequency.
  
- **Error Message:** External Power Supply Error, Current Protection.
- **Causes:** This message can appear when current consumption from built-in power supply grater than 250 mA.
- **Solutions:** Check target MCU power pins on short circuit.
  
- **Error Message:** WRONG SUBROUTINE CALL  
WRONG DEVICE TYPE
- **Causes:** These messages can appear when fatal problems with **UPD78-Programmer** hardware/firmware accrued.
- **Solutions:** Contact ETL technical support.



**Note:** **uPD78-Programmer** has Log Window which can be stored to file. To perform this operation right clicks on Log Window. Than click on “Save to uPD78prog.log file“ menu item. Now this file can be found in the same directory as **UPD78-Programmer** software. Log File can be send by E-mail to [techsupport@etlweb.net](mailto:techsupport@etlweb.net) for non described problem solution.

## 8. WARRANTY STATEMENT

ETL warrants that Product delivered shall conform to applicable. Report any defects for a 45 days period, from the applicable data on invoice.

## 9. APPENDIX

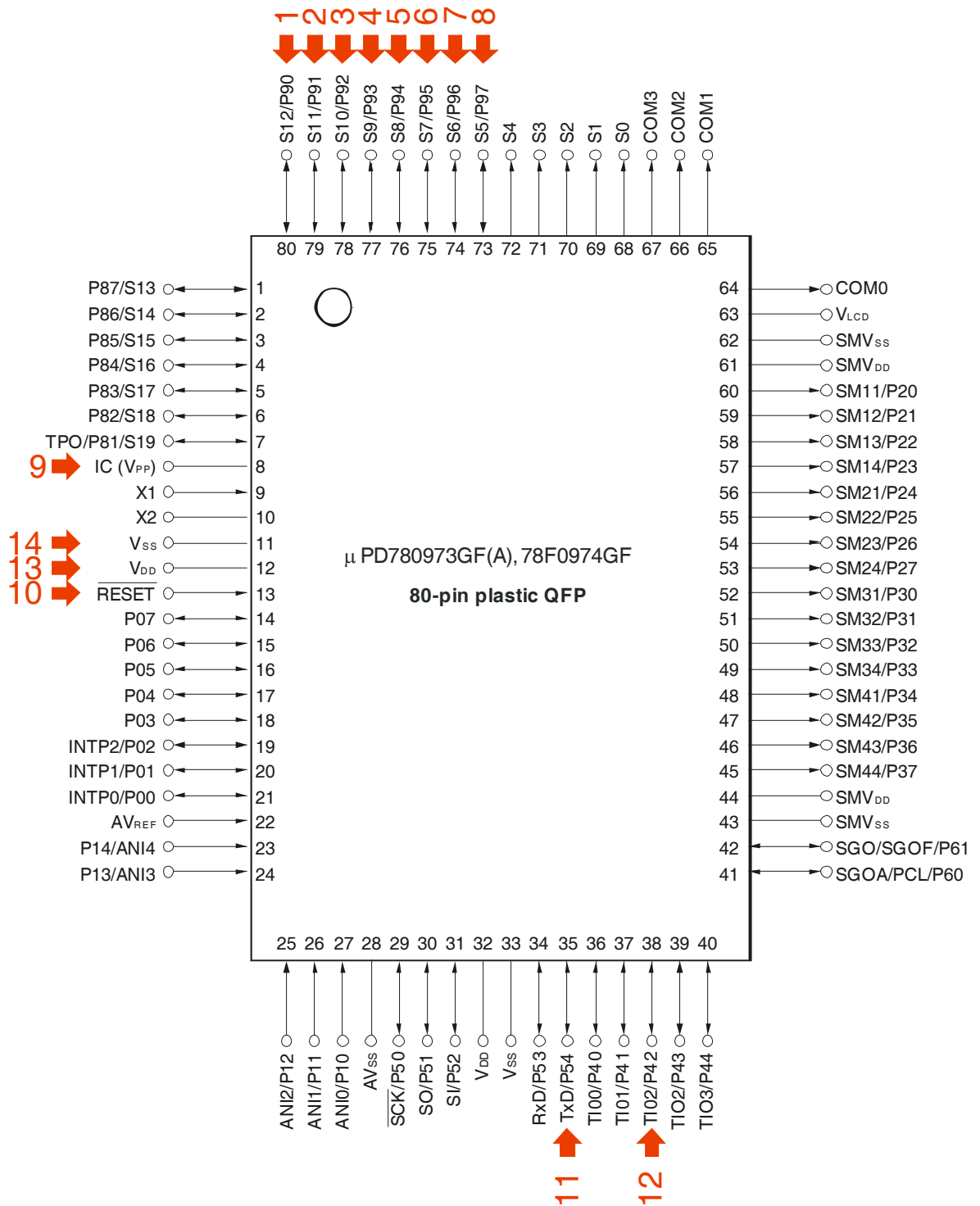

Figure 2. In-Circuit wiring diagram for uPD780973 MCU



**Note:** In RED color denoted lines from UPD78-Programmer that must be connected to target MCU.

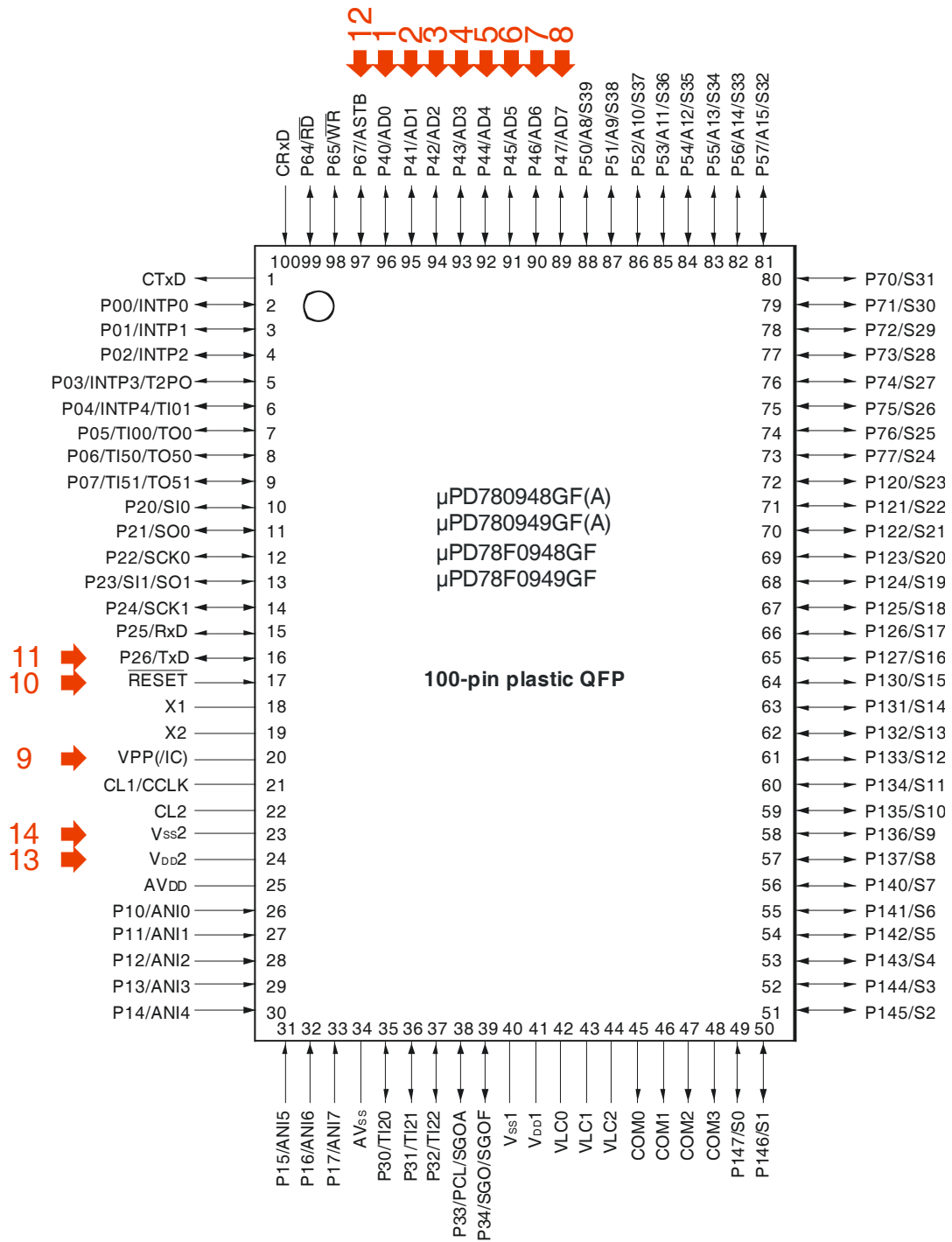

Figure 3. In-Circuit wiring diagram for uPD78(F)0948/49 MCU



**Note:** In RED color denoted lines from UPD78-Programmer that must be connected to target MCU.

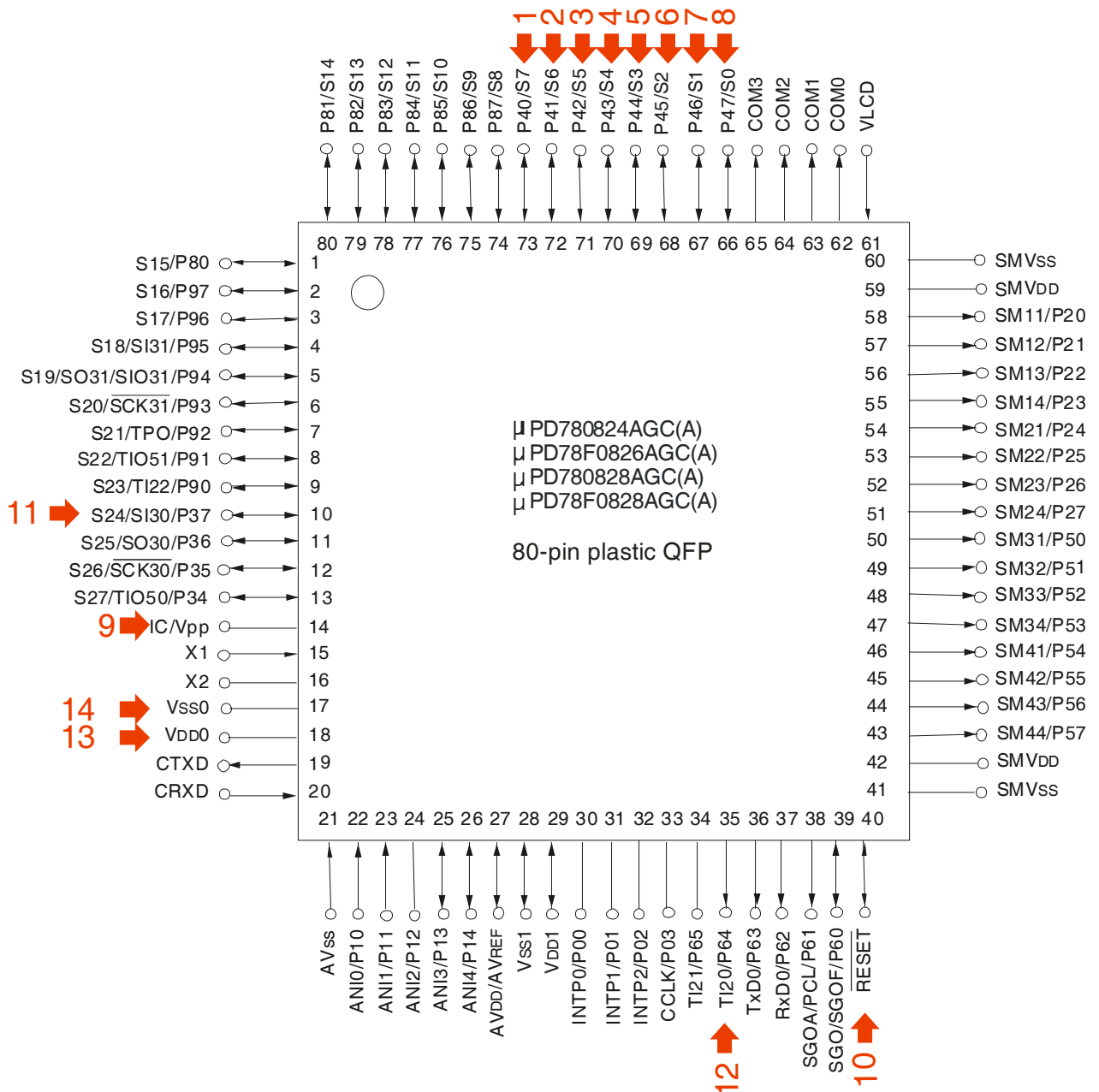

Figure 4. In-Circuit wiring diagram for uPD78(F)0828A MCU



**Note:** In RED color denoted lines from UPD78-Programmer that must be connected to target MCU.